

High Pressure Valves

MX Series II™ Modules
Manual

- ▶ Sample Injection
- ▶ Switching



High Pressure Valves Introduction

Rheodyne® valves fit virtually any flow control application. As you'll see from the table below and on the following pages, there are valves for preparative, analytical, nano, and microscale analysis in a variety of flow configurations. Pressure ratings of the valves in this chapter range from 125 psi (9 bar) to 15,000 psi (1034 bar).

Rheodyne is committed to providing cutting-edge, user-friendly products. MX Series II™ Modules are actuated electronically and can be easily adapted to existing instrumentation using contact closure, BCD, I²C, USB, or used as stand alone devices. Rheodyne's industry standard sample injectors and switching valves are designed for manual actuation. Locate the valve module and flow configuration of choice using the table below.



VALVE CONFIGURATIONS:

Valve Module	Flow Configuration	Connecting Tubing Size	Page
MXT Modules: Very High Pressure (<15,000 psi)	<ul style="list-style-type: none"> • 2-position, 6-port Switching • 6-position, 7-port Selection 	1/16" OD	84
MXP Modules: High Pressure (<6,000 psi)	<ul style="list-style-type: none"> • 2-position, 6-port Switching (analytical and nano scale) • 2-position, 6-port Vertical Port Switching • 6-position, 10-port Selection (analytical and nano scale) • 6-position, 7-port Selection 	1/32" or 1/16" OD	85
MXS Modules: Low Pressure (<125 psi)	<ul style="list-style-type: none"> • 2-position, 6-port Switching (analytical and prep scale) • 2-position, 6-port Double 3-Way Switching • 6-position, 7-port Selection (analytical and prep scale) • 10-position, 11-port Selection 	1/16" or 1/8" OD	86
Manual Sample Injectors	<ul style="list-style-type: none"> • Dual Mode Analytical, Micro and Preparative Scale Injector • Single Mode Analytical and Micro Scale Injectors 	.020", 1/16" or 1/8" OD	87-91
Manual Switching Valves	<ul style="list-style-type: none"> • 2-position, 6-port Switching • 2-position, 6-port 3-Way and 4-Way Switching • 6-position, 7-port Selection 	1/16" or 1/8" OD	88, 91-93

Genuine Rheodyne valve accessories are also featured in this chapter. Please see the pages indicated below for more information on these valve consumables:

- ▶ Vespel®, Tefzel®, and PEEK™ Rotor Seals; Stainless Steel, PEEK, and Propriety Material Stators (page 94)
- ▶ Rheodyne RheBuild® Kits (page 95)
- ▶ Stainless Steel and PEEK Sample Loops (page 96 and 97)
- ▶ Needle Port Accessories, Mounting Brackets, and the Rheodyne Wrench (page 100 and 101)

Upchurch Scientific® Micro Injection Port Adapters are also available on page 101.

ORDER ONLINE
www.idex-hs.com

MX Series II Valves Introduction

The new line of Rheodyne MX Series II automated fluidic valves provide productivity enhancing solutions for today's demanding analytical methods. Combine MX Series II modular valves with your current instrument to support complex fluid switching and sample injection needs.

Flexible Automation

The MX Series II modular valves are flexible to meet changing needs. Several options are available for connecting the valves to your analytical instrument or PC, including contact closure, BCD, I²C, and USB. Commands can be sent to the MX Series II valves using your chromatography software or TitanMX™ software (included) for timed-events programmability. MX Series II valves can be controlled remotely or operated manually using the push-button front panel with LED position indicator.

Increase Laboratory Capability

The MX Series II modules are available in a variety of flow paths including options for Nano, Semi-prep, Low Pressure, and Fast Chromatography applications up to 15,000 psi (1,034 bar). These modules feature the reliable automation of Titan valves, saving valuable resource time and increasing overall productivity.

Reduce Downtime

The High Pressure and Fast Chromatography MX Series II modular valves feature the Rapid Replacement Pod™ design for easy maintenance. The Rapid Replacement Pod is a complete, factory assembled and tested liquid-end, providing virtually zero downtime maintenance. Traditional RheoBuild® kits are also available. The Low Pressure MX Series II modular valves make changing fluidic connections quick and easy with our patented TitanEX™ fitting-less tubing connection system. These long-life polymer valves meet the reliability needs of demanding applications.

Versatile

MX Series II Modules are designed to increase productivity, expand laboratory capabilities, save time, and make life easier.

Rheodyne's MX Operating Manual including installation instructions is available at http://www.idex-hs.com/support/rheodyne/operating_instructions.aspx.

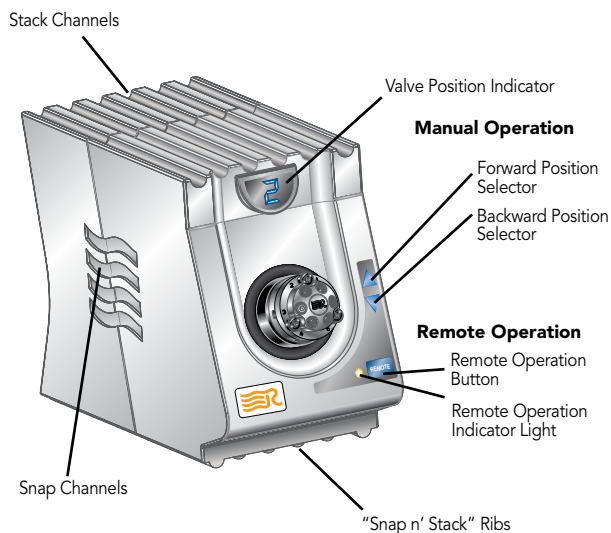

Application Note

Typical Solutions

- ▶ Sample Injection
- ▶ Two-Column Selection
- ▶ Alternating Column Regeneration
- ▶ High Speed Sample Enrichment
- ▶ High Speed Sample Clean Up
- ▶ Column Backflushing
- ▶ Multi-Dimensional Proteomic Peptide Separation
- ▶ Solvent Selection
- ▶ Fraction Collection
- ▶ Six Column Selection

These applications are discussed and illustrated in Rheodyne's MX Series II Solutions Guide at http://www.idex-hs.com/support/rheodyne/operating_instructions.aspx

MX SERIES II MODULE SPECIFICATIONS:

Maximum Pressure	MXT: 15,000 psi (1,034 bar) MXP: 6,000 psi (414 bar) MXX: 125 psi (9 bar)
Flow Passages	Nano: 0.10 mm (0.004") diameter Analytical: 0.25 mm (0.010") diameter Preparative: 1.5 mm (0.060") diameter
Power Requirements	100-120 VAC, 50-60 Hz
Regulatory Compliance	CE Mark
Remote Control	USB, I ² C, BCD, Level Logic
Operating Temperature	0°– 40°C, non-condensing
Storage Temperature	0°– 75°C
Dimensions (H x W x D)	117 mm x 76 mm x 128 mm (4.6" x 3.0" x 5.0")

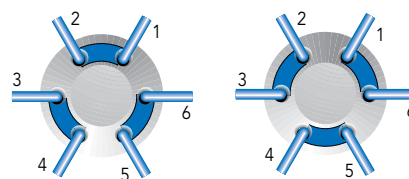

Position 1

Position 2

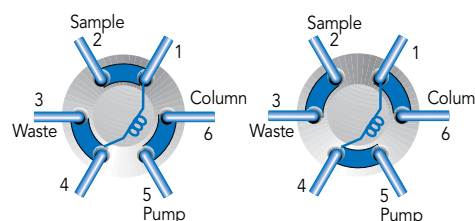
Flow path of MXT Two-Position, Six-Port Switching Valve.

Position 1

Position 2

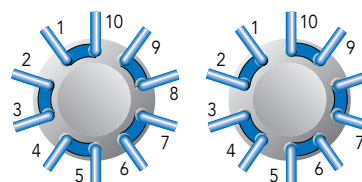
Flow path of MXT Two-Position, Six-Port as an Injection Valve.

Position 1

Position 2

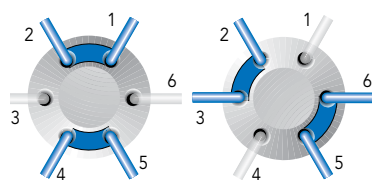
Flow path of MX Series II Two-Position, Ten-Port Switching Valve.

Position 1

Position 2

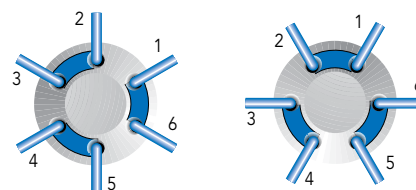
Flow Path of MX Series II Double Three-way Switching Valve.

Position 1

Position 2

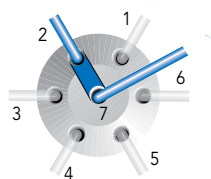
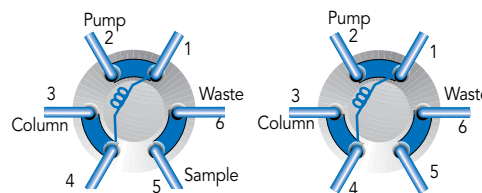
Flow path of MXP and MXX Two-Position, Six-Port Switching Valve.

Flow path of MX Series II Six-Position, Seven-Port Selector Valve.

Position 1

Position 2

Flow path of MXP and MXX Two-Position, Six-Port as an Injection Valve.

MXT Valves for Fast Chromatography

- ▶ New valves for ultra-high performance applications
- ▶ Can withstand up to 15,000 psi (1,034 bar)
- ▶ Made from Stainless Steel UltraLife™ material
- ▶ Available in a two-position and a six-position version

The MXT715-000 is a new 2-position, 6-port switching valve. This valve model is ideal for use as a two-column switching valve, enabling the same system to be used with more than one column to easily accommodate multiple users and applications. It can also be used in a traditional injection valve configuration and offers the Rheodyne patented MBB™ (Make-Before-Break) feature for improved reproducibility and system stability.

The MXT715-105 is a 6-position, 7-port selector valve. This valve is ideal for use in conjunction with a second identical valve for rapid column selection and applications which include more than two columns (see Application Note on page 162).

MXT valves feature UltraLife materials and are capable of withstanding up to 15,000 psi (1,034 bar). Each valve has minimal port-to-port volume of 0.3 µL. Each MXT valve comes complete with the fittings required to make initial tubing connections.

As an added benefit, MXT valves feature the popular Rapid Replacement Pod™ design for quick and easy maintenance. Within seconds you can easily remove the entire valve pod from the actuator and insert a spare pod, reconnect your fittings, and begin running your application.

Please Note: Please contact us regarding replacement rotor seals for the new MX Series II Valves.

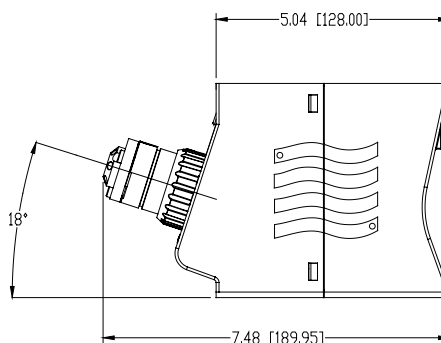
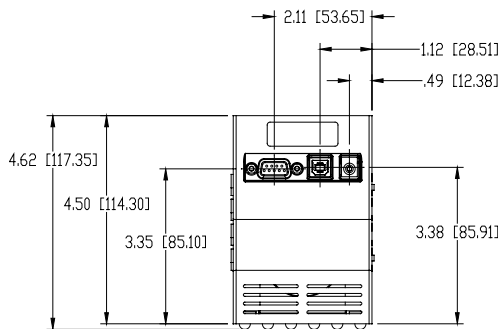

MXT Valve Dimensions - inches (mm)



TOP SELLER
see starred products in price block.

MXT HPLC VALVES		
		Material
★	MXT715-000 2-position, 6-port Switching Valve	Stainless Steel UltraLife
	MXT715-102 2-position, 10-port Switching Valve	Stainless Steel UltraLife
	MXT715-105 6-position, 7-port Selector Valve	Stainless Steel UltraLife
RAPID REPLACEMENT PODS		Qty.
	PD715-000 Rapid Replacement Pod for MXT715-000	ea.
	PD715-105 Rapid Replacement Pod for MXT715-105	ea.
FAST CHROMATOGRAPHY SAMPLE LOOPS*		
Volume		
	7755-300 5 µL Stainless Steel Sample Loop	ea.
	7755-301 10 µL Stainless Steel Sample Loop	ea.
	7755-302 20 µL Stainless Steel Sample Loop	ea.
	7755-303 50 µL Stainless Steel Sample Loop	ea.
	7755-304 100 µL Stainless Steel Sample Loop	ea.
REPLACEMENT FITTINGS		Qty.
	UH-193x Stainless Steel Ferrules	10-pk
	UH-196x Stainless Steel Nut, with UH-193 Ferrules, 10-32	10-pk

* All Fast Chromatography loops are rated to 15,000 psi.

MXP High Pressure Valves for HPLC

- ▶ New switching, selection, and injection valve models
- ▶ Can withstand up to 6,000 psi (414 bar)
- ▶ Chemically compatible for use with most mobile phase compositions
- ▶ Available with analytical and nano-scale flow paths

The Rheodyne® MXP7900-000 valve is the standard 2-position, 6-port switching valve designed for traditional HPLC and related techniques, used for traditional sample injections or to provide dual-column functionality in your system. For applications where biocompatibility is needed, consider the MXP9900-000, and when performing nano-scale applications, use the MXP7980-000 model.

The MXP7960-000 is a 2-position, 10-port switching valve that easily facilitates an alternating column regeneration process which can reduce your per-sample run time and can dramatically increase your overall sample throughput annually. For biocompatible applications, Rheodyne provides the MXP9960-000, and for nano-scale applications, the MXP7986-000 is available.

The MXP7970-000 is a 6-position, 7-port switching valve and is ideal for use in conjunction with a second identical valve to facilitate rapid column selection for applications using more than two columns.

MXP7920-000 is a special 2-position, 6-port injection valve featuring a vertical injection port and includes a needle-port fitting for syringe-loaded injections.

These MXP valves are capable of withstanding up to 6,000 psi (414 bar). Each standard valve features a small port-to-port volume of only 0.66 µL or less, while the nano-scale valves offer port-to-port volumes of less than 30 nL. Each valve comes complete with the fittings required to make initial tubing connections.

MXP valves feature the popular Rapid Replacement Pod™ design for quick and easy maintenance. Within seconds, you can easily remove the entire valve pod from the actuator and insert a spare pod, reconnect your fittings, and begin running your application.

Please Note: Please contact us regarding replacement rotor seals for the new MX Series II Valves.

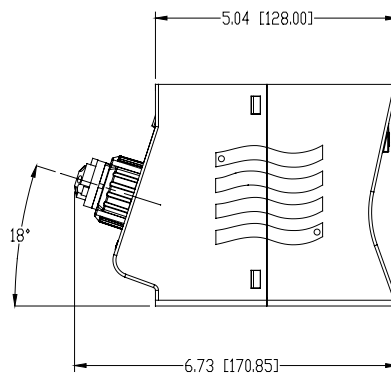
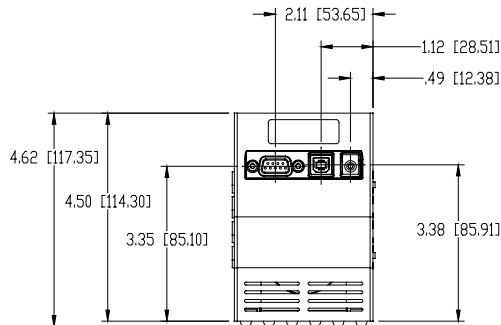

MXP Valve Dimensions - inches (mm)



TOP SELLER
see starred products in price block.

MXP HPLC VALVES		
		Material
★	MXP7900-000 2-position, 6-port Switching Valve	Stainless Steel DuraLife™
	MXP7920-000 2-position, 6-port Vertical Port Valve	Stainless Steel DuraLife
	MXP7960-000 2-position, 10-port Switching Valve	Stainless Steel DuraLife
	MXP7970-000 6-position, 7-port Selection Valve	Stainless Steel DuraLife
	MXP7980-000 2-position, 6-port Nano Switching Valve	Titanium DuraLife™
	MXP7986-000 2-position, 10-port Nano Switching Valve	Titanium DuraLife™
★	MXP9900-000 2-position, 6-port Switching Valve, Biocompatible	PEEK™
	MXP9960-000 2-position, 10-port Switching Valve, Biocompatible	PEEK
RAPID REPLACEMENT PODS		
		Qty.
	PD7900 Rapid Replacement Pod for MXP7900-000	ea.
	PD7920 Rapid Replacement Pod for MXP7920-000	ea.
	PD7960 Rapid Replacement Pod for MXP7960-000	ea.
	PD7970 Rapid Replacement Pod for MXP7970-000	ea.
	PD7980 Rapid Replacement Pod for MXP7980-000	ea.
	PD7986 Rapid Replacement Pod for MXP7986-000	ea.
	PD9900 Rapid Replacement Pod for MXP9900-000	ea.
	PD9960 Rapid Replacement Pod for MXP9960-000	ea.
REPLACEMENT FITTINGS		
		Qty.
	6000-209 Stainless Steel Standard Fittings, with 6000-210 Ferrules, 1/16", 10-32	10-pk
	6000-282 RheFlex® One-piece Fittings, 1/16", 10-32, PEEK, Natural	10-pk
	6000-360 M4 RheFlex Fittings, 1/32", PEEK, Natural	10-pk

MXX Low Pressure Valves

- ▶ New switching and selection valve models
- ▶ Can withstand up to 125 psi (9 bar)
- ▶ Rheodyne® proprietary polymer combination allows interface for long life
- ▶ All models accept 1/16" or 1/8" tubing and fittings

The MXX777-601 is the standard 2-position, 6-port switching valve designed for traditional low pressure chromatography and applications including sample injections and flow diversion for your system. All MXX valves accept either 1/16" or 1/8" tubing. Both ferrule sizes are shipped with all models. Analytical scale models come with 1/16" ferrules installed in the valve, and Large Bore models come with 1/8" ferrules installed. Simply unscrew the spanner and remove the ram to access and switch the ferrules to accommodate the other size tubing. For higher flow rates and semi-preparative applications the large bore MXX777-612 is available.

The MXX777-605 and MXX777-616 are 6-position, 7-port selection valves for analytical and semi-preparative applications, respectively. These valves work well for either pre-pump solvent selection or for post-column fraction collection. For even greater application versatility, try the MXX778-605 10-position, 11-port selection valve.

The MXX777-603 is a 2-position, 6-port valve with a "double three-way" flow path, offering two, 3-way diverter valves in one platform.

These MXX valves are capable of withstanding up to 125 psi (9 bar) and utilize proprietary RPC-7 proprietary polymer combination. An additional, unique feature of the low-pressure MXX valves is their fitting-less tubing connection, where no threaded fittings are required – only special ferrules, which are included to facilitate the initial tubing connections, are needed.

Please Note: Please contact us regarding replacement rotor seals for the new MX Series II Valves.

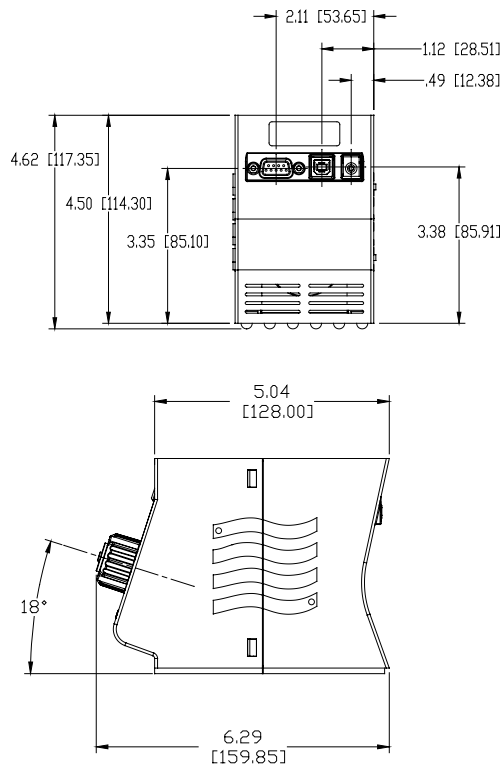

MXX Valve Dimensions - inches (mm)



MXX LOW PRESSURE VALVES

		Material
MXX777-601	2 position, 6-port Switching Valve	RPC-7*
MXX777-603	2 position Double Three-Way Valve	RPC-7
MXX777-605	6 position, 7-port Selection Valve	RPC-7
MXX777-612	2-position, 6-port Large Bore Valve	RPC-7
MXX777-616	6-position, 7-port Large Bore Selection Valve	RPC-7
MXX778-605	10-position, 11-port Selection Valve	RPC-7

REPLACEMENT FITTINGS

		Qty.
7770-039	Ferrules for 1/8" OD tubing	25-pk
7770-040	Ferrules for 1/8" tubing	50-pk
7770-041	Ferrules for 1/8" tubing	100-pk
7770-044	Ferrules for 1/16" OD tubing	25-pk
7770-045	Ferrules for 1/16" tubing	50-pk
7770-046	Ferrules for 1/16" tubing	100-pk
7770-124	O-rings for 1/16" OD tubing	25-pk

*RPC-7 Proprietary Polymer Combination

Sample Injectors

How to Choose a Sample Injector

Table I below compares the characteristics of Rheodyne manual sample injectors and will help you choose the most suitable model.

Types and Capabilities

Models ending in 25 (i.e. 7725) are dual mode injectors. Dual mode injectors can use both the partial-filling and the complete-filling method for loading the sample loop (See the “Sample Loop Loading” Application Note on page 98). They are variable volume injectors because they allow the loading of various sample volumes. These dual mode injectors, also called front-loading injectors, have a needle port for loading sample built into the handle. The unique Rheodyne injection port design allows the tip of the needle to connect directly to the sample loop for no sample loss during loading.

Models ending in 10 (i.e. 7010) are single mode injectors. Single mode injectors use only the complete-filling method to load the sample loop. They are called fixed loop injectors as the sample loop size determines the sample volume. These injectors require a Loop Filler Port accessory (page 96), as a needle port is not built into the valve handle. There is not a direct connection between the syringe and the sample loop. Therefore, an excess of sample must be used to overfill the Loop Filler Port and completely fill the sample loop.

Models with an “i” suffix (i.e. 7725i) are identical to the models with the same numbers but the “i” designates a built-in position sensing switch. The switch provides the chromatograph with a reproducible start signal to mark the injection time in the data system.

The reproducibility of manual sample injectors depends on operator skill, syringe calibration, and the loading method. Partial-filling method is typically reproducible to 1.0% relative standard deviation (RSD). Complete-filling method is reproducible to 0.1% RSD for loops ≥ 5 µL.

Scale, Sample Volume, and Loop Size

Analytical scale models are for conventional columns with samples from 1.0 µL to 5.0 mL. Microscale models are for 1.0 mm and 2.0 mm inner diameter columns. Model 8125 has a sample range of 0.1 µL to 500 µL, and can be used for both analytical and micro columns. Preparative scale models are for columns with diameters from 1 to 10 cm, and operate at high flow rates with samples from 100 µL to 20 mL.

Liquid Contact Materials

All models have a polymeric rotor seal of Vespel® (pH 0 to 10 tolerance), Tefzel® or PEEK™ (both pH 0 to 14). Stators are 316 stainless steel or PEEK. Most models have an inert ceramic stator face assembly.

Make-Before-Break (MBB®)

Models incorporating Rheodyne’s patented MBB architecture design provide uninterrupted flow when switching between LOAD and INJECT positions. MBB greatly reduces transient pressure shocks and is beneficial for flow-sensitive detectors, fragile columns, and pumps. Models 7725, 9725, 3725, and “i” versions contain the MBB design.

ChromTRAC™ Mapping

Selected Rheodyne manual valves contain the industry standard ChromTRAC Mapping to color-code your fluid connections. You can identify each port by its colored number, which designates the ChromTRAC color for each system component. Simply coordinate the ChromTRAC colored fittings with the port color.

TABLE I. CHARACTERISTICS OF RHEODYNE MANUAL SAMPLE INJECTORS:

Type & Capabilities	Scale	Partial Filling Volumes (Range)	Sample Loop Sizes (Range)	Liquid-Contact Materials	Max. psi (bar) ¹	Max. T (°C)	MBB ²	Model ³
Dual Mode Can load the loop by two methods: 1) Partial filling – syringe determines volume without wasting sample 2) Complete filling – loop determines volume by over filling loop	Analytical	1 µL – 2.5 mL	2 µL – 5.0 mL	316 SST, Vespel	7,000 (483)	80°	Yes	7725, 7725i
		1 µL – 5.0 mL	2 µL – 10 mL	PEEK, Tefzel, ceramic	5,000 (340)	50°	Yes	9725, 9725i
	Micro	0.1 µL – 500 µL	5 µL – 1.0 mL	316 SST, PEEK, Vespel, ceramic	7,000 (483)	80°	No	8125
Single Mode Can load the loop by one method: Complete filling – loop determines volume by over filling loop	Preparative	100 µL – 10 mL	2.0 mL – 20 mL	316 SST, PEEK	5,000 (340)	50°	Yes	3725(i)-038
				PEEK	4,000 (276)	50°	Yes	3725, 3725i
	Analytical	Not Applicable	5 µL – 5.0 mL	316 SST, Vespel	7,000 (483)	150°	No	7000
				5 µL – 10 mL	PEEK, Tefzel, Ceramic	5,000 (340)	50°	No
Micro	Not Applicable	0.5 µL – 5 µL	316 SST, Vespel	7,000 (483)	150°	No	7410	
			0.2 µL – 1 µL	316 SST, Vespel	7,000 (483)	80°	No	7520

SST = Stainless Steel
¹ This is the maximum pressure to which the valve can be adjusted. Some models are shipped from the factory set for lower pressures.
² MBB (Make-Before-Break) is a patented Rheodyne design that provides uninterrupted flow when switching between LOAD and INJECT. MBB also greatly reduces transient pressure shocks.
³ Models with an “i” suffix have a built-in position sensing switch. Models 8125 and 9010 also have a built-in switch.

TABLE II. SPECIFICATIONS OF RHEODYNE MANUAL SWITCHING VALVES:

Model	Stator Passage Diameter	Factory Set Pressure	Maximum Field Set Pressure	Maximum Temperature (°C)
7000, 7010, 7030, 7040 (SST)	0.6 mm (0.024")	5,000 psi (340 bar)	7,000 psi (483 bar)	150°
7060 (SST)	0.4 mm (0.016")	5,000 psi (340 bar)	7,000 psi (483 bar)	80°
7000L, 7030L, 7040L, 7060L (SST)	1.0 mm (0.040")	3,000 psi (207 bar)	5,000 psi (340 bar)	150° (7060L : 80°)
9010, 9030, 9060 (PEEK)	0.4 mm (0.016")	5,000 psi (340 bar)	5,000 psi (340 bar)	50°
3000, 3030 (PEEK)	1.0 mm (0.040")	3,000 psi (207 bar)	4,000 psi (276 bar)	50°
3000-038, 3030-038 (SST)	1.0 mm (0.040")	4,000 psi (276 bar)	5,000 psi (340 bar)	50°

SST = Stainless Steel

High Pressure Switching Valves

Rheodyne offers high pressure manual switching valves to simplify procedures and improve the speed, resolution, and sensitivity of HPLC analysis. The switching valves are available in 316 stainless steel and PEEK™, with a choice of 1.6 mm (1/16") or 3.2 mm (1/8") ports. See Table II on page 87 for valve specifications.

Column Selection

The six-position switching valves are used for column selection. These valves substitute one column for another without the need to manually disconnect the plumbing. This makes it easy to designate a separate column for each analysis, which helps eliminate equilibration delays, reduce interferences and prolong column life. Turning the valve handle selects the column desired for a particular analysis. Columns switched to off-line are automatically sealed at both ends.

Column Switching

The two-position switching valves can be used to reroute mobile phase during the chromatographic run without changing separation techniques. They can also be used to perform sequential separations with different columns and/or mobile phases.

Although the model 7000 is the most commonly used and versatile switching valve, other models have specific uses such as for three-way or four-way switching patterns.

Many models have flow passages available in both standard bore and large bore (designated with an "L" suffix). L models use 1/16" fittings and tubing but have larger flow passage diameters than non-L models. As such, L models can accommodate higher flow rates. Large bore tubing can be used when the pressure drop must be limited. Large bore valves have a lower pressure drop than standard bore valves when both valve sizes accommodate the same flow rate (see graph below).

PRESSURE DROP VS. FLOW RATE:

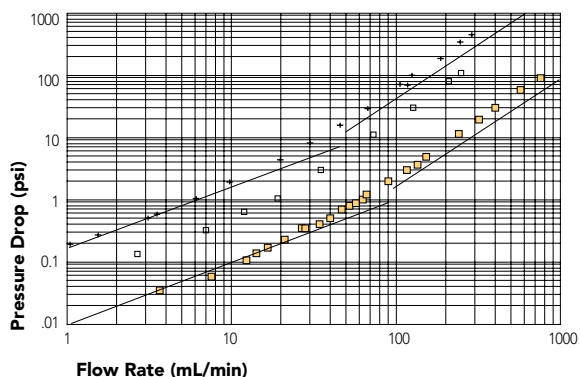

Pressure drop vs. flow rate for model 7000 and model 7000L (large-bore) valves; water at 20°C. Experimental measurements: The flow channel is one stator inlet port, one rotor seal groove, one stator outlet port and two connecting tubes. Solid squares = (1.0 mm 7000L valve) + (two 1.0 mm x 5.0 cm tubes). Open squares = (0.6 mm 7000 valve) + (two 1.0 mm x 5.0 cm tubes). Cross mark = (0.6 mm 7000 valve) + (two 0.5 mm x 5.0 cm tubes). Solid lines are theoretical values for 10 cm long tubes of 1.0 mm and 0.5 mm ID. Pressure drop is in units of psi.

Effects of Valves and Tubing on Resolution

The effect of tubing on analytical and microscale analyses can be significant. Since dispersion caused by tubing is proportional to the fourth power of diameter, large bore tubing should be avoided when performing analytical scale or microscale analyses. Tubing ID size ≤ 0.25 mm (0.010") is recommended.

Consider a system with a Rheodyne injector and column switching valves and analytical columns with small-bore connecting tubing. The chromatograms below, made using a typical analytical chromatograph, show these effects. Scheme A is the control (injector \rightarrow column \rightarrow detector) with no valve in the system. In Schemes B and C, two model 7060 Six-Position Switching Valves were placed side by side (injector \rightarrow valve #1 \rightarrow column \rightarrow valve #2 \rightarrow detector).

The injector and detector were connected to these valves by the same tubing used in the control. The extra tubing pieces required to connect the valves to the column were a 10 cm length for valve #1-to-column, and a 35 cm length for column-to-valve #2. The diameters of these tubes are indicated in the experimental details, below.

EFFECTS OF VALVES AND TUBING ON RESOLUTION:

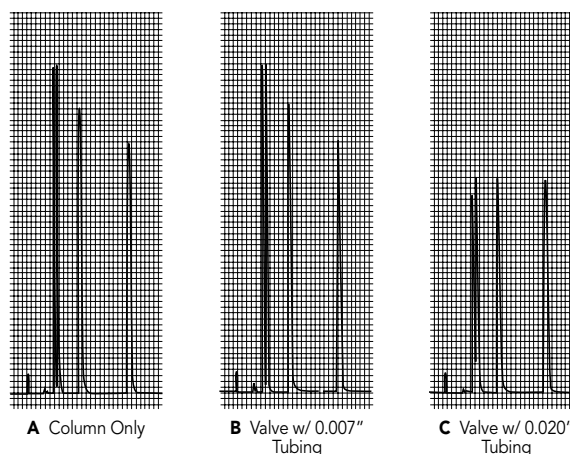

These chromatograms show the loss of resolution caused by the addition of two model 7060 column selection valves when using connection tubes of two different inside diameters. Conditions for all cases: 4.6 mm x 12.5 cm column, 5 μ m C-18 packing, 50% acetonitrile in water, 2.0 mL/min, 21°C, 5.0 μ L sample partial filled into a model 7125 injector, 10 cm x 0.18 mm (0.007") bore injector outlet tube (to column or valve), 10 cm x 0.18 mm bore detector inlet tube (from column or valve), low dispersion 1.0 cm path UV detector cell, 0.2 sec detector time constant. See text above for details.

Micro-Scale Injector

Model 8125

Model 8125 is the Rheodyne® manual valve solution to your microscale analyses. Made of 316 stainless steel and designed for 1.0 mm (0.04") and 2.0 mm (0.08") microbore columns, the adaptable injector is also compatible with analytical columns (3.0-5.0 mm, 0.12-0.20"). Model 8125's built-in position sensing switch provides the chromatograph with a reproducible start signal.

This versatile injector allows both partial-filling method (reproducibility of 1.0% RSD) and complete-filling method (reproducibility of 0.1% RSD). For more information, see the "Sample Loop Loading" and "Fluidic Movement in Tubes" and "Using Proper Syringe Needles" Application Notes on pages 98, 99 and 100, respectively. To save loading time into the 8125's small flow passages, the largest loop recommended for the complete-filling method is 200 µL. This dual-mode capability allows varying sample volumes for your microscale analyses.

Micro-scale 8125 sample loops use 0.020" (0.5 mm) OD tubing instead of the conventional 1/16" (1.6 mm) OD tubing to provide low-dispersion performance. The versatile 8125 can also accommodate 1.6 mm (1/16") OD tubing. The presence of a mixing cavity between the loop and injector port is less likely when using the smaller size tubing. Cavities may cause high dispersion and peak distortion. Valve flow passages are 0.3 mm (0.013") in diameter.

The table below compares the improved resolution using the 8125 to analytical scale injectors, such as the 7725. The improvement is greatest with relatively unretained (low k') peaks.

Flow switching occurs at a flat interface between a polymeric rotor seal and a ceramic stator face assembly. You can have confidence in the long seal life of this genuine Rheodyne part combination.

A simple, three-step sample injecting operation involves inserting the syringe into the needle port while in the LOAD position and turning the handle to INJECT. The sample is on its way through your system and when the handle returns to LOAD, the injector is ready for the next injection. The flow path positions are illustrated to the right. In addition, see the "Using Proper Syringe Needles" Application Note on page 100.

See Table I in Introduction to Rheodyne Manual Valves on page 87 for detailed specifications.

Please Note: The 8125 ships with a 5µL stainless steel sample loop and one set of 10-32 RheFlex® Stainless Steel Fittings (3-long, 1-extra long). Replacements and alternatives are available on pages 96 – 97 and 19, respectively.

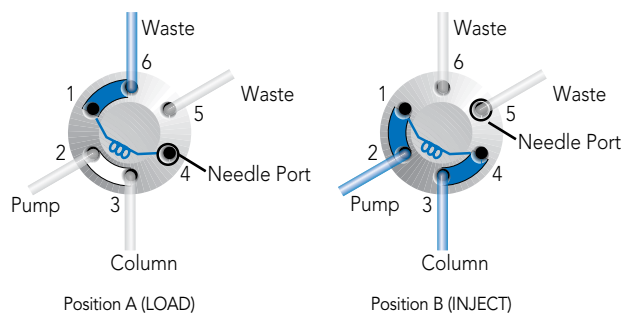

Flow paths of the LOAD and INJECT positions of model 8125 sample injector for microscale analyses.

COMPARISON OF OBSERVED COLUMN PLATES OF RHEODYNE ANALYTICAL AND MICROSCALE INJECTORS:

	7725	8125	Δ
k' = 0.6	2930	5054	72%
k' = 1.5	4653	6904	48%
k' = 7.9	7875	8305	5.0%

UV detector: 1 µL volume, 4 mm path. Sample volume: 2 µL, partial-filling method. Column: 2 mm ID x 100 mm long, 4 µm C-18. True plates of column = 11,570.

MICRO-SCALE SAMPLE INJECTOR

8125	Dual Mode, Micro-Scale Injector	Stator Material
		Stainless Steel

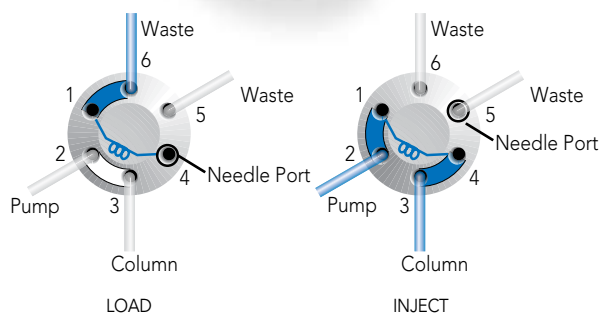

Flow paths of the LOAD and INJECT positions of models 7725(i) and 9725(i) sample injectors.

Analytical Injectors

Models 7725, 7725i, 9725 and 9725i

The 316 stainless steel models 7725 and 7725i, and PEEK™ models 9725 and 9725i are Rheodyne®'s most advanced manual sample injectors for analytical HPLC. Specialized features include:

- ▶ The Rheodyne patented Make-Before-Break (MBB®) architecture allows continuous flow between LOAD and INJECT positions which greatly reduces transient pressure shocks that disrupt your system.
- ▶ Wide, 30° port angles offer easier access to fittings using the Rheodyne Wrench (Part # 6810 on page 101).
- ▶ Front-end pressure screw makes it easy to adjust and maintain pressure.
- ▶ Capability of a reproducible 2 μL sample injection with a 2 μL internal sample loop. See page 97 for internal sample loops.
- ▶ A built-in position sensing switch ("i" versions) provides the chromatograph with a reproducible start signal.

The patented Rheodyne MBB valve design is illustrated below. In the LOAD position, mobile phase flow from pump port to column port travels through both the rotor seal groove and the MBB passage (Position A). As the rotor seal grooves rotate to change from LOAD to INJECT, there is continuous mobile phase flow through both one rotor seal groove and the MBB passage (Position B) until the rotation stops and both rotor seal grooves are connected by the loop. Sample flow begins through the loop to the column just as all flow stops through the MBB passage (Position C). Sample flow never enters the MBB passage. Valve flow passages are 0.6 mm (0.024") in diameter.

The injector contains a patented Rheodyne needle port design that connects the tip of the syringe needle directly to the sample loop ensuring zero sample loss, no cross-contamination, and syringe accuracy. These versatile front-loading injectors allow both partial-filling method (reproducibility of 1.0% RSD) and complete-filling method (reproducibility of 0.1% RSD). This dual mode capability allows varying sample volumes for your analytical analyses. For more information, see the "Sample Loop Loading," "Fluidic Movement in Tubes" and "Using Proper Syringe Needles" Application Notes on pages 98, 99 and 100, respectively.

Flow switching occurs at a flat interface between a polymeric rotor seal and a ceramic stator face assembly in both the stainless steel and PEEK models. You can have confidence in the long seal life of this genuine Rheodyne part combination.

A simple, three-step operation involves inserting the syringe into the needle port while in the LOAD position and turning the handle to INJECT. The sample is on its way through your system and when the handle returns to LOAD, the injector is ready for the next injection.

See Table I in Introduction to Rheodyne Manual Valves on page 87 for detailed specifications.

View the online product bulletin - http://www.idex-hs.com/support/rheodyne/product_bulletins.aspx

Please Note: The valves on this page ship with a 20 μL sample loop and one set of 10-32 RheFlex® Two-Piece Fittings (3-long, 1-extra long). The material of these accessories matches that of the stator material (see below). Replacements and alternatives are available on pages 96 – 97, 14, 16 and 19.

PATENTED RHEODYNE MBB DESIGN:

Flow paths of model 7725(i) and 9725(i) with patented Rheodyne MBB design.

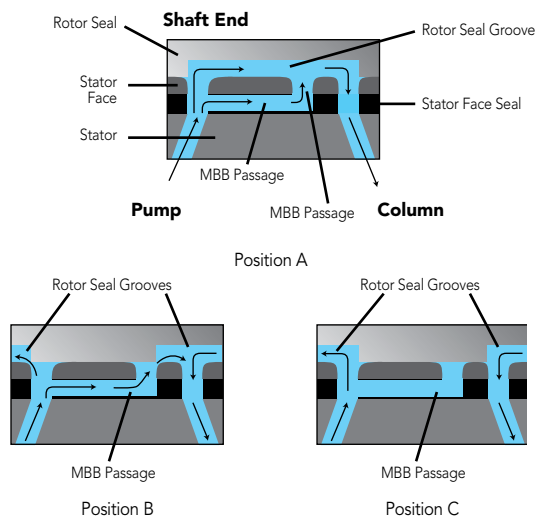

ANALYTICAL-SCALE SAMPLE INJECTORS

		Stator Material
★ 7725	Dual Mode, Analytical Injector	Stainless Steel
★ 7725i	Dual Mode, Analytical Injector with Switch	Stainless Steel
9725	Dual Mode, Analytical Injector	PEEK
★ 9725i	Dual Mode, Analytical Injector with Switch	PEEK

Preparative-Scale Injectors

Models 3725-038, 3725i-038, 3725 and 3725i

Models 3725-038 and 3725i-038 (316 stainless steel) and 3725 and 3725i (biocompatible PEEK™) are the most suitable manual valves to use with large sample volumes, high flow rates, and preparative columns sized 1.0-10 cm (0.4–4.0”) in diameter. The ports accommodate 1/8” (3.2 mm) OD tubing, and 1/16” (1.6 mm) OD tubing with the Adapter accessory (Part # 6000-076, page 52). The 1.0 mm (0.040”) diameter passages allow flow rates of 10 to 100 mL/minute with virtually no pressure drop. These versatile injectors allow both partial-filling method (reproducibility of 1.0% RSD) and complete-filling method (reproducibility of 0.1% RSD). This dual-mode capability allows variable sample volumes for your preparative scale analyses. For more information, see the “Sample Loop Loading,” “Fluidic Movement in Tubes” and “Using Proper Syringe Needles” Applications Notes on pages 98, 99 and 100, respectively. Please note: Rheodyne® Preparative-Scale Injectors require a 16 gauge needle.



The “i” version injectors’ built-in position sensing switch provides the chromatograph with a reproducible start signal.

These preparative scale injectors incorporate Rheodyne’s patented Make-Before-Break (MBB®) architecture allowing continuous flow between LOAD and INJECT positions which greatly reduces disruptive transient pressure shocks to your system.

A simple, four-step operation involves inserting the syringe into the needle port while in the LOAD position and turning the handle to INJECT. The sample is on its way through your system. To prevent mobile phase from ejecting out of the needle port, remove the syringe and place the plug attached to the handle into the needle port while still in INJECT position. Turn the handle back to LOAD, and remove the plug for the next injection. The flow path positions are illustrated below.

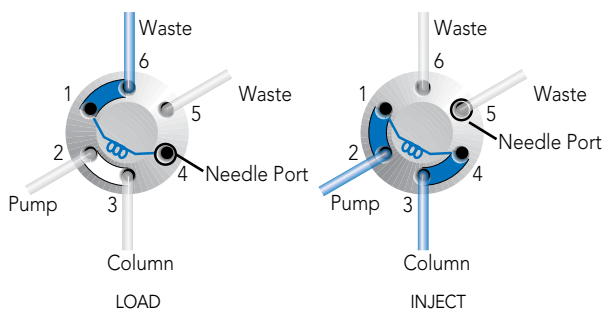

Flow paths of the LOAD and INJECT positions of models 3725(i) and 3725(i)-038 sample injectors.

See Table I in Introduction to Manual Valves on page 87 for detailed specifications.

View the online product bulletin - http://www.idex-hs.com/support/rheodyne/product_bulletins.aspx

Please Note: The valves on this page ship with a 10 mL sample loop and one set of 5/16-24 RheFlex® Fittings. The material of these accessories matches that of the stator material. Replacements and alternatives are available on pages 96–97, 16 and 19. Alternative 10-32 fittings for use with 1/16” OD tubing (with Adapter 6000-076, page 52) are listed on pages 14–16.

Two-Position Switching Valves

Models 7000(L), 3000-038, 3000 and 9010

The versatile two-position, six-port Rheodyne® valves are available in 1/16” and 1/8” port sizes, and 316 stainless steel and PEEK™ versions. These valves redirect flow among columns during the chromatographic run. They are also useful for selecting between two columns as shown in the Application Note on page 162.

Models 7010 Stainless Steel and 9010 PEEK sample injector can convert to a six-port switching valve functionally identical to model 7000 by removing the loop.

View the online product bulletin -

http://www.idex-hs.com/support/rheodyne/product_bulletins.aspx

Please Note: The valves on this page ship with one set of 10-32 (1/16”) or 5/16-24 (1/8”) RheFlex Two-Piece Fittings. The 7010 and 9010 also ship with a 20 µL sample loop. The material of these accessories matches that of the stator material (see below). Replacements and alternatives are available on pages 14, 16 and 19.



PREPARATIVE-SCALE SAMPLE INJECTORS

		Stator Material
3725-038	Dual Mode, Preparative Injector	Stainless Steel
3725i-038	Dual Mode, Preparative Injector with Switch	Stainless Steel
3725	Dual Mode, Preparative Injector	PEEK
3725i	Dual Mode, Preparative Injector with Switch	PEEK

TWO-POSITION SWITCHING VALVES

		Stator Material
7000	Two-Position, 6-Port Switching Valve (1/16”)	Stainless Steel
7000L	Two-Position, 6-Port Large Bore Switching Valve (1/16”)	Stainless Steel
7010	Single Mode, Analytical Injector (1/16”)	Stainless Steel
3000-038	Two-Position, 6-Port Switching Valve (1/8”)	Stainless Steel
3000	Two-Position, 6-Port Switching Valve (1/8”)	PEEK
9010	Single Mode, Analytical Injector (1/16”)	PEEK

Three-Way Switching Valves

Models 7030(L), 9030, 3030-038 and 3030

Two-position, six-port valves with a double three-way switching pattern are available in 1/16" and 1/8" port sizes, and 316 stainless steel and PEEK™ versions.

See Introduction to High Pressure Switching Valves on page 88 for detailed specifications.

View the online product bulletin for valves - http://www.idex-hs.com/support/rheodyne/product_bulletins.aspx



Flow diagram of a Three-Way Switching Valve.

Four-Way Switching Valves

Models 7040 and 7040L

The two-position, six-port 316 stainless steel valves contain an external loop that exchanges the flow pattern from Ports 2 to 3 and 4 to 6 to Ports 2 to 6 and 4 to 3. This flow pattern facilitates applications such as column backflushing.

Other Rheodyne® valves can convert to a four-way valve. Model 9010 PEEK sample injector (page 91) becomes four-way by changing the loop to connect Ports 1 and 5. Model 3000 PEEK switching valve (page 87) becomes four-way by adding an external loop connecting Ports 1 and 5.

View the online product bulletin for valves - http://www.idex-hs.com/support/rheodyne/product_bulletins.aspx



Flow diagram of a Four-Way Switching Valve.

Please Note: The valves on this page ship with one set of 10-32 (1/16") or 5/16-24 (1/8") RheFlex® Two-Piece Fittings. The material of these accessories match that of the stator material. Replacements and alternatives are available on pages 14, 16 and 19.

THREE- AND FOUR-WAY SWITCHING VALVES			Stator Material
7030	Three-Way, Switching Valve (1/16")		Stainless Steel
7030L	Three-Way, Large Bore Switching Valve (1/16")		Stainless Steel
9030	Three-Way, Switching Valve (1/16")		PEEK
3030-038	Three-Way, Switching Valve (1/8")		Stainless Steel
3030	Three-Way, Switching Valve (1/8")		PEEK
7040	Four-Way, Switching Valve (1/16")		Stainless Steel
7040L	Four-Way, Large Bore, Switching Valve (1/16")		Stainless Steel

Six-Position Switching Valves

Models 7060(L) and 9060

Rheodyne®'s Six-Position Switching Valves make complex HPLC analyses easier. Two manually operated six-position valves allow convenient selection among six columns for different analytical methods on the same chromatograph. The advantages of using these valves over manually changing columns are: immediate selection, no wear on fittings from repeated tightening, and having both ends of the off-line columns sealed by the valves (keeping them on stand-by for future use).

For manual column selection, the center port of one valve connects to an injector. Turning the valve handle directs flow into one of up to six columns connected to the valve's six peripheral ports. A second six-position valve connects to the column outlets to select the operating column effluent and to direct it to the detector.

The sixth port may be used for a bypass/flush-out tube. This connection permits rapid mobile phase changeover without exposing any column to a mobile phase other than the one with which it is routinely used. See the drawing to the right for a six column selection application set-up.

These six-position valves are available in 316 stainless steel and PEEK™ and in 10-32 coned port sizes for 1/16" OD tubing.

Large bore, "L" versions are used to avoid excessive pressure drops when using high flow rates. See graph on page 88 for pressure drop information. These models also can be used for mobile phase selection by connecting the center port to a pump inlet.

See *Introduction to High Pressure Switching Valves* on page 88 for detailed specifications.

View the online product bulletin for the 7060(L) and 9060 Valves - http://www.idex-hs.com/support/rheodyne/product_bulletins.aspx



Application Note

Six column selection using two model 7060 switching valves.

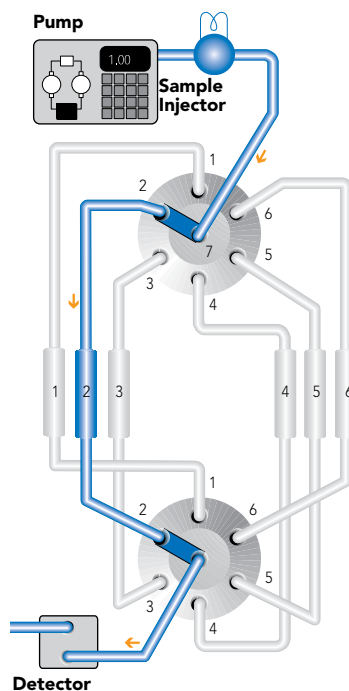

Please Note: The valves on this page ship with one set of 10-32 (1/16") RheFlex® Two-Piece Fittings. The material of these accessories matches that of the stator material (see below). Replacements and alternatives are available on pages 14, 16 and 19.

ORDER ONLINE
www.idex-hs.com



SIX-POSITION SWITCHING VALVES

		Stator Material
7060	Six-Position, Switching Valve (1/16")	Stainless Steel
7060L	Six-Position, Large Bore, Switching Valve (1/16")	Stainless Steel
9060	Six-Position, Switching Valve (1/16")	PEEK

Rheodyne® Rotor Seals and Stators

The rotor seal is the polymeric disc that makes a high pressure seal against the stator or stator face seal. The seal wears with use and is one of the only parts that may need routine replacement.

Genuine Rheodyne rotor seals are unmatched in performance and product life. These rotor seals are products of rigid manufacturing and quality assurance procedures. Only genuine Rheodyne parts ensure the continued precision performance of Rheodyne valves.

Rheodyne engineers develop exacting rotor seal specifications and designs that must pass tougher-than-real-world standards of performance. Rheodyne rotor seals fully meet the demanding requirements of day-to-day manual instrument and automated laboratories.

Rheodyne rotor seals are made from proprietary-blended polymers, formulated specifically for resistance to repetitive chemical and physical stresses of the entire 0 to 14 pH range. Vespel® blend rotor seals have an operating pH range from 0 to 10. Tefzel® blend and PEEK™ blend rotor seals have a pH range from 0 to 14. Strong oxidizing acids such as concentrated nitric and sulfuric are not compatible with PEEK.

Stators are available in 316 stainless steel, PEEK and proprietary materials. Rheodyne stator materials have been researched and selected for their physical and mechanical strengths. Stators need replacement only if the ports or sealing surfaces become damaged. Avoid damage from use of improper injection needles by referring to the "Using Proper Syringe Needles" Application Note on page 100.

Please Note: Rotor seals for MX Series II™ Modules are available in RheoBuild® Kits on page 95. Stators for MX Series II Modules are available on this page. MX (Series I) Module rotor seals are available in RheoBuild Kits on page 95. Stators are available at www.idex-hs.com/rheodyne



TOP SELLER
see starred products
in price block.

Application Note

How to Select the Right Rotor Seal

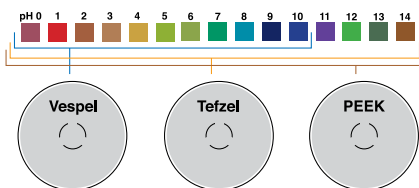

The standard rotor seal in many Rheodyne manual valves is made from a Vespel blend. This polyimide has low wear and high chemical resistance. Vespel tolerates a pH range of 0 to 10. Solutions more basic than pH 10 dissolve Vespel which damages the rotor seal. If you use any solutions above pH 10, Rheodyne recommends a PEEK blend rotor seal. PEEK offers a high chemical resistance and versatility, and will tolerate the entire pH range from 0 to 14. Tefzel blend rotor seals are appropriate for use in applications where PEEK is not generally acceptable, such as when methylene chloride or DMSO in higher concentrations is being used.



VESPEL BLEND ROTOR SEALS

- ★ **7010-039** Vespel Rotor Seal for models 7010, 7000, 7040
- 7030-003** Vespel Rotor Seal for model 7030
- 7060-070** Vespel Rotor Seal for models 7060, 7066
- 7125-047** Vespel Rotor Seal for models 7125, 7725
- 7410-038** Vespel Rotor Seal for model 7410
- 7413-013** Vespel Rotor Seal for model 7413
- 8125-038** Vespel Rotor Seal for model 8125

TEFZEL BLEND ROTOR SEALS

- 7010-071** Tefzel Rotor Seal for models 7010, 7010-087, 7000, 7040
- 7030-015** Tefzel Rotor Seal for model 7030
- 7060-074** Tefzel Rotor Seal for models 7060, 7066, 9060
- 7125-079** Tefzel Rotor Seal for models 7125, 7125-081, 7725
- 7410-075** Tefzel Rotor Seal for model 7410
- 8125-097** Tefzel Rotor Seal for model 8125
- 9010-051** Tefzel Rotor Seal for model 9010
- 9125-082** Tefzel Rotor Seal for models 9125, 9725

PEEK BLEND ROTOR SEALS

- 3030-005** PEEK Rotor Seal for models 3030, 3030-038
- 3710-008** PEEK Rotor Seal for models 3000, 3000-038, 3710, 3710-038
- 3725-018** PEEK Rotor Seal for models 3725, 3725-038
- 7610-011** PEEK Rotor Seal for models 7610-400, 7610-600

STATORS FOR MX SERIES II™ MODULES

- 7980-004** Stator for model MXP7980-000
- 7770-229** Stator for model MXP7920-000
- 7986-004** Stator for model MXP7986-000
- 7900-179** Stator for model MXP7900-000
- 7900-146** Stator for model MXP9900-000
- 7900-183** Stator for model MXP7970-000
- 7960-014** Stator for model MXP7960-000
- 9960-002** Stator for model MXP9960-000
- 7123-548** Stator for model MXT715-000
- 7123-550** Stator for model MXT715-105
- 7123-568** Stator for model MXT715-102

STATORS FOR OTHER RHEODYNE VALVES

- 3725-006** Stator for models 3725, 3710-038, 3000-038 and 3030-038
- 3725-085** Stator for models 3725-038, 3710-038, 3000-038 and 3030-038
- 7010-040** Stator for models 7010, 7125, 7000, 7030 and 7040
- 7010-066** Stator for models 7125-081 and 7010-087
- 7060-039** Stator for models 7060 and 7066
- 7123-047** Stator for model PR/EV500-100
- 7123-127** Stator for model PR/EV750-107
- 7123-128** Stator for model PR/EV700-107
- 7123-142** Stator for model PR/EV500-104
- 7123-145** Stator for model PR/EV550-104
- 7123-147** Stator for model PR/EV550-100
- 7123-148** Stator for model PR/EV500-101
- 7123-180** Stator for model PR703-100
- 7123-221** Stator for model PR753-100
- 7123-223** Stator for model PR/EV700-112
- 7410-041** Stator for models 7410 and 7413
- 7610-048** Stator for model 7610-600
- 7650-002** Stator for model PR/EV700-102
- 7725-010** Stator for model 7725
- 7750-038** Stator for model PR/EV700-100
- 8125-098** Stator for model 8125
- 9060-016** Stator for model 9060
- 9125-043** Stator for models 9125, 9010, 9030 and 9725
- 9650-009** Stator for model PR/EV750-102
- 9750-021** Stator for model PR/EV750-100

RheBuild Kits

RheBuild Kits with genuine Rheodyne® parts are available for all Rheodyne products. Included in each individualized RheBuild Kit are all parts, tools, and instructions to maintain precision performance of your particular Rheodyne product. RheBuild Kits eliminate individual part ordering.



Application Note

How to Avoid Pressure Transients

Air in the sample loop can cause an instantaneous system pressure drop that eventually returns to a normal level. Air causes the pressure to drop when the injector moves from the LOAD to the INJECT position. When large sample loops ($\geq 100 \mu\text{L}$) are partially loaded, air present in the needle port tube is pushed into the sample loop (see Figure 1). Air can also enter the sample loop from siphoning which occurs when the vent line is higher than the injection port. In either case, upon injection, the system pressure collapses the air bubble, causing pressure to drop momentarily.

A pressure drop in the system caused by air results in changes in retention time, artifact peaks, and affects column performance.

Avoid pressure drops by removing the air in the needle port tube. Do this by flushing about 1 mL of mobile phase with a luer syringe with needle port cleaner. Keep the needle port tube filled with mobile phase by occasional flushing. Adjust the vent line(s) so the outlet is at the same horizontal level as the needle port (see Figure 2). For additional injection troubleshooting, refer to the Rheodyne Troubleshooting Guide for HPLC Injection Problems. You may download the Guide from the IDEX Health & Science web site: www.idex-hs.com under Support. You can also request a copy by using the reply card at the back of this publication.

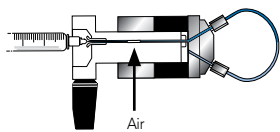

Figure 1 Air present in the needle port tube is pushed by the syringe during loading into the sample loop.

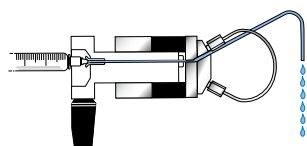

Figure 2 Pathway of the flushing mobile phase using the Needle Port Cleaner, Part # 7125-054 (see page 100) when the injector is in INJECT.

RHEBUILD KITS FOR MX SERIES II™ VALVES

- 7970-999** RheBuild Kit for MXP7970-000
- 7920-999** RheBuild Kit for MXP7920-000 and MXP7900-000
- 7961-999** RheBuild Kit for MXP7960-000
- 79801-999** RheBuild Kit for MXP7980-000
- 79861-999** RheBuild Kit for MXP7986-000
- 7900-999** RheBuild Kit for MXP9900-000
- 7960-999** RheBuild Kit for MXP9960-000
- 7150-999** RheBuild Kit for MXT715-100
- 7152-999** RheBuild Kit for MXT715-102
- 7155-999** RheBuild Kit for MXT715-105

RHEBUILD KITS FOR MANUAL VALVES

- 3725-999** RheBuild Kit for models 3725, 3725i, 3725-038, 3735i-038
- 7010-996** Conversion Kit including Stator Face Assembly for model 7010
- 7010-997** RheBuild Kit including Stator for model 7010
- 7010-999** RheBuild Kit for model 7010 and 7010-type Valves
- 7125-999** RheBuild Kit for models 7125 and 7126
- 7125Ti-999** RheBuild Kit for model 7125-081
- 7410-999** RheBuild Kit for model 7410
- 7520-999** RheBuild Kit for models 7520 and 7526
- 7725-999** RheBuild Kit for models 7725 and 7725i
- 8125-999** RheBuild Kit for models 8125 and 8126

RHEBUILD KITS FOR MX SERIES I™ VALVES

- 7900-999** RheBuild Kit for models MX7900-000, MX9900-000, MX9925-000
- 7960-999** RheBuild Kit for model MX7960-000
- 7980-999** RheBuild Kit for model MX7980-000
- 7984-999** RheBuild Kit for model MX7984-000
- 7986-999** RheBuild Kit for model MX7986-000

RHEBUILD FOR PEEK™ VALVES

- 9010-999** RheBuild Kit for model 9010
- 9125-999** RheBuild Kit for models 9125 and 9126
- 9725-999** RheBuild Kit for models 9725 and 9725i

RHEBUILD KITS FOR LABPRO® & EV AUTOMATED FLUIDIC INSTRUMENTS

- 1001-999** RheBuild Kit for model PR100-101
- 1005-999** RheBuild Kit for model PR/EV100-105
- 1006-999** RheBuild Kit for model PR/EV100-106
- 5001-999** RheBuild Kit for models PR/EV500-101 and PR/EV550-101
- 5100-999** RheBuild Kit for models PR/EV500-100 and PR/EV550-100
- 5104-999** RheBuild Kit for models PR/EV500-104 and PR/EV550-104
- 7004-999** RheBuild Kit for models PR/EV700-104 and PR/EV750-104
- 7112-999** RheBuild Kit for models PR/EV700-112 and PR/EV750-112
- 7501-999** RheBuild Kit for models PR/EV700-100 and PR/EV750-100
- 7502-999** RheBuild Kit for models PR/EV700-102 and PR/EV750-102
- 7507-999** RheBuild Kit for models PR/EV700-107 and PR/EV750-107
- 7531-999** RheBuild Kit for models PR703-100 and PR753-100

Rheodyne® Stainless Steel Sample Loops

These high quality stainless steel sample loops have burr-free, square-cut ends to ensure a flush connection to valve ports. The size designations of loops are nominal. The actual volumes can differ from the theoretical designations because of the 0.001" (± 0.025 mm) tolerance of the metal tubing bore.

Accuracy of large metal loops (1.0 mm, 0.040" bore) is about $\pm 5\%$, intermediate loops (0.5 mm, 0.020" bore) $\pm 10\%$, and small loops (0.2 mm, 0.007" bore) $\pm 30\%$.

Since both standards and unknowns are usually analyzed using the same sample loop, knowledge of the actual, accurate volume is rarely needed. If the sample loop volume must be known, it is best to calibrate the loop in place on the valve so the flow passages in the valve are also taken into account. An alternative to calibration is to use a dual mode injector and partial-filling method of loading. See the "Sample Loop Loading" Application Note on page 98.

Model 7725 Injector loops are not interchangeable with loops for the model 7125. The port angle for the 7725 is 30° whereas the port angle for the 7125 is 20° requiring the loops to have a different shape.

Model 8125 Micro-Scale Sample Injector requires special loops in the 5.0 μL to 50 μL range. The 8125 sample loops are made with 0.5 mm (0.020") OD tubing.

Stainless steel sample loops are supplied with unswaged fittings. The two ends of the loop must be completely bottomed in the injector ports before the ferrule is swaged onto the loop. Swaging each end separately and then replacing the ends in their respective ports of the same valve ensures that the loop ends are bottomed into the ports. A fitting made up in one port may leave an undesirable cavity in another port. As all ports vary in all valves, careful attention to loop installation is important. Please see the "How to Properly Install Sample Loops" Application Note on page 98 for more information.



**ORDER
ONLINE**
www.idex-hs.com



RHEODYNE STAINLESS STEEL LOOPS FOR MXT715-000

	Volume	Tubing
7755-300	5 μL Sample Loop	0.18 mm (0.007") ID x 1/16" OD
7755-301	10 μL Sample Loop	0.30 mm (0.012") ID x 1/16" OD
7755-302	20 μL Sample Loop	0.30 mm (0.012") ID x 1/16" OD
7755-303	50 μL Sample Loop	0.51 mm (0.021") ID x 1/16" OD
7755-304	100 μL Sample Loop	0.51 mm (0.021") ID x 1/16" OD

RHEODYNE STAINLESS STEEL LOOPS FOR 7125, 7010 INJECTORS (DO NOT USE FOR 7725)

	Volume	Tubing
7020	5 μL Sample Loop	0.18 mm (0.007") ID x 1/16" OD
7021	10 μL Sample Loop	0.30 mm (0.012") ID x 1/16" OD
7022	20 μL Sample Loop	0.51 mm (0.020") ID x 1/16" OD
7023	50 μL Sample Loop	0.51 mm (0.020") ID x 1/16" OD
7024	100 μL Sample Loop	0.51 mm (0.020") ID x 1/16" OD
7025	200 μL Sample Loop	0.76 mm (0.030") ID x 1/16" OD
7026	500 μL Sample Loop	0.76 mm (0.030") ID x 1/16" OD
7027	1.0 mL Sample Loop	0.76 mm (0.030") ID x 1/16" OD
7028	2.0 mL Sample Loop	1.0 mm (0.040") ID x 1/16" OD
7029	5.0 mL Sample Loop	1.0 mm (0.040") ID x 1/16" OD
1876	10 mL Sample Loop	2.0 mm (0.080") ID x 1/8" OD
1877	20 mL Sample Loop	2.0 mm (0.080") ID x 1/8" OD

RHEODYNE STAINLESS STEEL LOOPS FOR 3725-038, 3725I-038 INJECTORS

	Volume	Tubing
3065-018	2.0 mL Sample Loop	2.0 mm (0.080") ID x 1/8" OD
3065-019	5.0 mL Sample Loop	2.0 mm (0.080") ID x 1/8" OD
3065-023	10 mL Sample Loop	2.0 mm (0.080") ID x 1/8" OD
3065-025	20 mL Sample Loop	2.0 mm (0.080") ID x 1/8" OD

RHEODYNE STAINLESS STEEL LOOPS FOR 7725, 7725i, PR/EV700-100, PR/EV703-100, MX MODULE INJECTORS (DO NOT USE FOR 7125)

	Volume	Tubing
7755-020	5 μL Sample Loop	0.18 mm (0.007") ID x 1/16" OD
7755-021	10 μL Sample Loop	0.30 mm (0.012") ID x 1/16" OD
7755-022	20 μL Sample Loop	0.30 mm (0.012") ID x 1/16" OD
7755-023	50 μL Sample Loop	0.51 mm (0.020") ID x 1/16" OD
7755-024	100 μL Sample Loop	0.51 mm (0.020") ID x 1/16" OD
7755-025	200 μL Sample Loop	0.76 mm (0.030") ID x 1/16" OD
7755-026	500 μL Sample Loop	0.76 mm (0.030") ID x 1/16" OD
7755-027	1.0 mL Sample Loop	0.76 mm (0.030") ID x 1/16" OD
7755-028	2.0 mL Sample Loop	1.0 mm (0.040") ID x 1/16" OD
7755-029	5.0 mL Sample Loop	1.0 mm (0.040") ID x 1/16" OD
1876	10 mL Sample Loop	2.0 mm (0.080") ID x 1/8" OD
1877	20 mL Sample Loop	2.0 mm (0.080") ID x 1/8" OD

RHEODYNE STAINLESS STEEL LOOPS FOR 8125 INJECTOR (USE 7755-024 TO 7755-029 FOR VOLUMES > 50 μL)

	Volume	Tubing
8020	5 μL Sample Loop	0.20 mm (0.008") ID x 1/16" OD
8021	10 μL Sample Loop	0.20 mm (0.008") ID x 1/16" OD
8022	20 μL Sample Loop	0.25 mm (0.010") ID x 0.020" OD
8023	50 μL Sample Loop	0.30 mm (0.012") ID x 1/16" OD

REPLACEMENT RHEFLEX® AND SUPER FLANGELESS™ FITTINGS

		Qty.
6000-082	Nut/Ferrule Set, SST, 5/16-24, for 1/8" OD loops*	ea.
6000-083	Ferrules, SST, for 1/8" OD loops*	5-pk
6000-210	Ferrules, SST, for 1/16" OD loops	10-pk
6000-211	Nut/Ferrule Sets, SST, 10-32, for 1/16" OD loops	10-pk
P-331	Super Flangeless Nut, PEEK™, for 1876, 1877 loops	ea.
P-350x	Super Flangeless Ferrules, PEEK/SST, for 1/8" OD 1876, 1877 loops	10-pk
P-654	Adapter, PEEK, for 1/8" OD 1876 and 1877 loops	ea.

*Except 1/8" OD 1876 and 1877 loops.

Rheodyne® PEEK™ Sample Loops

Flexible PEEK sample loops are alternatives to stainless steel loops. PEEK loop ends are provided with clean, straight cuts for easy valve installation.

PEEK polymer is inert to almost all organic solvents and is biocompatible, giving PEEK loops added versatility. Rheodyne uses natural PEEK for these sample loops. Like metal loops, the size designations of PEEK loops are nominal. The actual volumes can differ from the theoretical designations because of the ± 0.05 mm (0.002") tolerance of the tubing bore. Accuracy of large PEEK loops (0.8 mm, 0.030" bore) is about $\pm 14\%$, intermediate loops (0.5 mm, 0.020") $\pm 21\%$, and small loops (0.2 mm, 0.007") $\pm 65\%$.

PEEK loops are also supplied with unswaged RheFlex® fittings but do not require the same swaging precaution. The fittings can reposition along the loop tubing when the fitting reinserts in the ports for correct loop installation.

Please Note: Several of our PEEK Sample Loops can also be used with Valco/VICI® sample injectors. Please refer to the product listing on this page to aid selection.

PEEK Physical Strength Characteristics

Although PEEK material is compatible with virtually all solvents, there are many factors that affect burst pressure of PEEK tubing. Factors such as increases in inner diameter, temperature, exposure time, and concentration of organic solvents affect the degradation of PEEK. Other solvents such as THF, methylene chloride and DMSO cause PEEK tubing to swell while concentrated nitric acid and sulfuric acid weaken the tubing.

Valco/MCI-Compatible Stainless Steel Sample Loops

Valco-Compatible Stainless Steel Loops are manufactured by Upchurch Scientific®. These loops are designed for use with Valco valve models CW6 and EC6W. Each loop has burr-free, polished ends and is passivated and flushed with reagent-grade methanol to ensure cleanliness.

Loops made with 1/16" OD tubing come complete with F-287 SealTight™ Fittings, which are pressure rated to 9,000 psi (620 bar)¹. The fittings and adapters that accompany the 1/8" OD sample loops are rated to 1,000 psi (69 bar)¹. Volumes are stated at $\pm 10\%$, with exact calibration services available. Each sample loop we calibrate is documented and supplied with a calibration certificate.

¹ These pressure ratings reflect the performance of the fittings, not the port or valve in which they are used.

Upchurch Scientific manufactures many products designed as direct replacements for OEM components. Reference to these manufacturers does not imply their endorsement of our products.



PEEK LOOPS FOR 3725, 3725i INJECTORS

	Volume	Tubing
3055-018	2.0 mL Sample Loop	1.6 mm (0.062") ID x 1/8" OD
3055-019	5.0 mL Sample Loop	1.6 mm (0.062") ID x 1/8" OD
3055-023	10 mL Sample Loop	2.0 mm (0.080") ID x 1/8" OD
3055-025	20 mL Sample Loop	2.0 mm (0.080") ID x 1/8" OD

PEEK LOOPS FOR 9725, 9010, PR/EV750-100, PR/EV753-100 INJECTORS

	Volume	Bore/Tubing	Valco No.
7123-227	1 µL Sample Loop (model PR/EV750-100 only)	internal groove	NA
7755-015	2 µL Sample Loop (9725 only)	internal groove	NA
9055-020	5.0 µL Sample Loop	0.18 mm (0.007") ID x 1/16" OD	SL5CWPK
9055-021	10 µL Sample Loop	0.25 mm (0.010") ID x 1/16" OD	SL10WPK
9055-022	20 µL Sample Loop	0.25 mm (0.010") ID x 1/16" OD	SL20WPK
9055-023	50 µL Sample Loop	0.51 mm (0.020") ID x 1/16" OD	SL50WPK
9055-024	100 µL Sample Loop	0.51 mm (0.020") ID x 1/16" OD	SL100WPK
9055-025	200 µL Sample Loop	0.51 mm (0.020") ID x 1/16" OD	NA
9055-026	500 µL Sample Loop	0.76 mm (0.030") ID x 1/16" OD	SL500WPK
9055-027	1.0 mL Sample Loop	0.76 mm (0.030") ID x 1/16" OD	SL1KCWPK
9055-028	2.0 mL Sample Loop	0.76 mm (0.030") ID x 1/16" OD	SL2KCWPK
9055-029	5.0 mL Sample Loop	0.76 mm (0.030") ID x 1/16" OD	NA
9055-033	10 mL Sample Loop	0.76 mm (0.030") ID x 1/16" OD	NA

PEEK LOOPS FOR 7725, 7725i, PR/EV700-100

	Volume	Bore
7123-227	1 µL Sample Loop (model PR/EV700-100 only)	internal groove
7755-015	2 µL Sample Loop (models 7725 and 7725i only)	internal groove

REPLACEMENT RHEFLEX FITTINGS FOR PEEK LOOPS

		Qty.
6000-251	Ferrules, Natural PEEK, for 1/16" OD loops	10-pk
6000-254	Nut/Ferrule Sets, Natural PEEK, 10-32, for 1/16" OD loops	10-pk
6000-078	Nut/Ferrule Set, Natural PEEK, 5/16-24, for 1/8" OD loops	ea.
6000-079	Ferrules, Natural PEEK, for 1/8" OD loops	5-pk

VALCO/VICI-COMPATIBLE STAINLESS STEEL LOOPS FOR C6W, EC6W INJECTORS

	Volume	Tubing	Valco No.
1750	5 µL Sample Loop	0.18 mm (0.007") ID x 1/16" OD	SL5CW
1751	10 µL Sample Loop	0.25 mm (0.010") ID x 1/16" OD	SL10CW
1752	15 µL Sample Loop	0.25 mm (0.010") ID x 1/16" OD	SL15CW
1755	20 µL Sample Loop	0.51 mm (0.010") ID x 1/16" OD	SL20CW
1758	25 µL Sample Loop	0.51 mm (0.010") ID x 1/16" OD	SL25CW
1759	50 µL Sample Loop	0.51 mm (0.020") ID x 1/16" OD	SL50CW
1762	100 µL Sample Loop	0.51 mm (0.020") ID x 1/16" OD	SL100CW
1778	200 µL Sample Loop	0.76 mm (0.030") ID x 1/16" OD	NA
1763	250 µL Sample Loop	0.76 mm (0.030") ID x 1/16" OD	SL250CW
1764	500 µL Sample Loop	0.76 mm (0.030") ID x 1/16" OD	SL500CW
1770	1 mL Sample Loop	0.76 mm (0.030") ID x 1/16" OD	SL1KCW
1772	2 mL Sample Loop	1.02 mm (0.040") ID x 1/16" OD	SL2KCW
1775	5 mL Sample Loop	2.03 mm (0.080") ID x 1/8" OD	SL5KCW
1776	10 mL Sample Loop	2.03 mm (0.080") ID x 1/8" OD	SL10KCW

Application Note

How to Properly Install Sample Loops Stainless Steel

Stainless steel sample loops are supplied with fittings that are not swaged onto the tube. It is important that the loop be completely bottomed in the injector port before the ferrule is swaged onto the tube. The depth of the tubing holes may vary slightly from port to port and from valve to valve. A fitting made up in one port may leave a small cavity in another port. The cavity causes high dispersion and peak distortion such as fronting, tailing, or broadening. It is good practice to label loop ends so they will be replaced in the same, respective ports that were used in swaging the ferrules. Hint: swaging ferrules separately on each side, into each respective valve port makes loop installation easier.

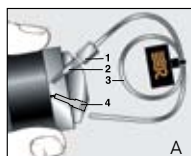

To install the sample loop:

- Take one end of the loop and place the nut (1) and ferrule (2) onto the tubing (3) with the threaded portion of the nut and tapered portion of the ferrule toward the end. See Figure A.
- Insert the tubing into port (4). Confirm that the tubing is bottomed in the valve port as shown in Figure A.
- While firmly pressing down on the tubing, hand-tighten the nut as tight as possible.
- With the Rheodyne® Wrench (see page 96), designed especially for fittings, tighten one quarter turn past finger tight. Remove the loop to confirm the ferrule is swaged onto the tube.
- Repeat steps a-d with the other end of the loop while the swaged end remains outside the valve port. See Figure B.
- Reinstall each end of the loop to their respective ports. See Figure C.



Figure 1 Cut-away view of stainless steel sample loop installation.

RheFlex® PEEK™ Fittings and PEEK Tubing

PEEK loop installation requires steps a-c in the stainless steel section above. Finger tightening of PEEK fittings is adequate to make a leak-free connection. The slotted backside of the ferrule (1) is squeezed down onto the tube (2) by the mating conical surface in the nut (3). See Figure 2. The nut and ferrule can both be reused many times. Unlike ordinary fittings, the unique RheFlex PEEK design, specifically the angles and surface contacts between the ferrule and nut, prevents the nut from gripping the ferrule and twisting both the ferrule and the tube during tightening. Otherwise, such twisting stresses the PEEK tubing and lowers the pressure rating of the tubing.

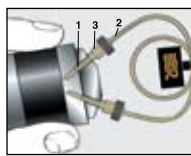

The ferrule can slide and reposition itself along the tube when the fitting is reinserted into a port. It is important that the PEEK tubing is completely bottomed in the injector port before the fittings are tightened to avoid leaving an undesired cavity. Both stainless steel and PEEK sample loops are listed on pages 96 – 97.

Figure 2 Cut-away view of PEEK sample loop installation.

Application Note

Sample Loop Loading: Partial-Filling vs. Complete-Filling

Partial-Filling

Use the partial-filling method if you need to conserve sample, or if you want to vary sample volume frequently.

In partial-filling, the syringe sets the volume injected onto the column. There is no sample waste, and the volume injected onto the column is equal to that dispensed from the syringe. Reproducibility is 1.0% relative standard deviation (RSD). The volume of the sample loaded is limited to half the sample loop volume. For example, the most you can load into a 200 μL sample loop is 100 μL . See Figure 1. This limitation is because fluidic movement in tubes affects reproducibility. See the “Fluidic Movement in Tubes” Application Note on page 99.

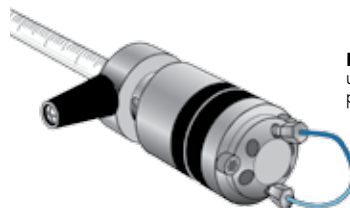

Figure 1 The sample loop can fill up to half the loaded volume in partial-filling method.

Complete-Filling

Use the complete-filling method if you have plenty of sample, if you do not vary sample volume, or if you need high reproducibility.

In complete-filling, the loop sets the volume loaded onto the column. Use excess sample (two to five loop volumes) to replace all the mobile phase in the loop. See Figure 2. Change the loop to vary the sample volume. Reproducibility is typically 0.1% RSD for loop sizes $\geq 5 \mu\text{L}$. Accuracy is limited as loop volumes are nominal.

Q: “Which method should I use and which Rheodyne sample injectors use this method?”

A: There are two types of injectors available: dual mode and single mode. Dual mode injectors allow both partial- and complete-filling whereas single mode injectors allow only complete-filling. See Sample Injectors on pages 89 – 91.

If you are collecting experimental data, sample is scarce, and/or you want to use different sample volumes, a dual mode injector with a large volume sample loop is appropriate. Only dual mode injectors allow the partial-filling method for easily varying your volumes (up to half your sample loop volume) by setting the syringe volume. Once you begin routine analysis, and/or you have an abundance of sample, either a dual mode or single mode injector is appropriate. Both types of injectors allow the complete-filling method in which you overfill the sample loop. Complete-filling maximizes the reproducibility of your results.

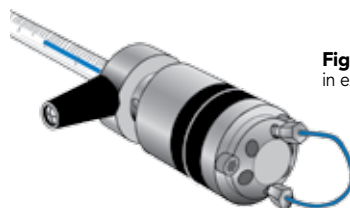

Figure 2 The sample loop is filled in excess in complete-filling method.

Application Note

Fluidic Movement in Tubes

Q: “Why can I load only up to half of the volume of the loop in partial-filling method?”

A: Sample occupies 2 μL of loop for every 1 μL loaded from the syringe. For example, 10 μL of sample spreads out over the entire length of a 20 μL loop. Any additional sample loaded will overflow the end of the loop and exit out to waste. Reproducibility is poor because the volume of sample in the loop is different from the known volume originally loaded by your syringe.

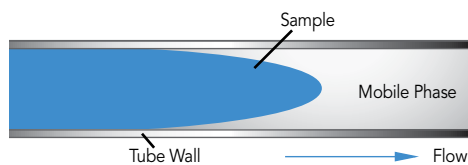

Figure 1 Schematic of sample flow through mobile phase between tubing walls.

Fluid spreads in a parabolic shape through a tube instead of moving in one plug because the velocity is different at the center of the tube than at the walls. The velocity at the center of the tube is twice the average velocity, and near the wall the velocity is almost zero, creating a parabolic shape. This fluidic movement is called laminar flow. See Figure 1.

In dual mode injectors (see “Sample Loop Loading” Application Note on page 98) the sample from the syringe needle loads directly into the sample loop. The sample volume is known since there is no sample waste. The laminar flow phenomenon accounts for the shape of the plot as shown in Figure 2. Note that the plot has three regions:

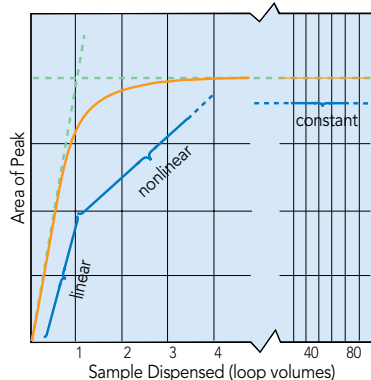

Figure 2 Sample mass (observed peak area) vs. volume of sample dispensed from the syringe, in units of loop volumes, injected onto the column from a Rheodyne® dual mode injector such as model 7725.

a) Partial-Filling Region. When the volume dispensed is less than half the loop volume, the curve is linear. Sample has not reached the end of the loop. Within this region, performance depends on the syringe and operator.

b) Nonlinear Region. When the volume dispensed is between half the loop volume and about two loop volumes, the curve is nonlinear. Sample is lost from the loop, so reproducibility is poor. If you dispense a volume equal to the loop size, you are in this region of poor performance.

c) Complete-Filling Region. When the volume of sample dispensed is several loop volumes, the loop contains only pure sample, undiluted by residual mobile phase. Within this region, reproducibility is highest.

In the single mode injectors the sample must pass through a connecting passage before it reaches the sample loop. Since some of the sample dispensed from the syringe remains in the connecting passageway, an unknown amount enters the sample loop. Therefore, single mode injectors achieve high reproducibility only by using the complete-filling method.

Application Note

How to Find and Fix Common Sample Injector Leaks

Leaks cause valuable sample loss. Nobody wants that. The key to the valve holding pressure is the integrity of the sealing surfaces. If there is a scratch on the sealing surface, or the needle seal in the rotor seal is damaged, a leak may appear. It is also important to realize what appears to be a leak can instead be a result of siphoning. The following are the three most common situations in which fluid leaks occur.

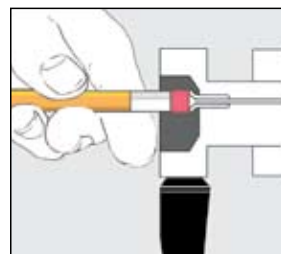

Figure 1 To reform the needle seal, push the eraser end of a pencil against the needle port.

1. If fluid leaks out of the needle port only while loading the loop (i.e., while pushing down on the plunger of the syringe), the problem is most likely that the needle seal or the needle port fitting in the loop filler port is not gripping the syringe needle tightly enough. Tighten the needle seal grip by pushing with the eraser end of the pencil on the needle port (See Figure 1). The tightening reduces the hole diameter of the needle seal and port fitting.

2. If fluid leaks continuously from the needle port or vent lines and/or from the stator-to-stator ring interface, replace the rotor seal and/or stator face assembly. Scratches on the rotor seal or cracks in the stator face assembly allow mobile phase to escape and cause cross port leakage. Genuine Rheodyne replacement rotor seals are listed on page 94.

3. If fluid leaks from the needle port and/or vent lines but eventually stops, the cause is most likely siphoning and not a leak. Siphoning occurs if the vent lines are lower or higher than the needle port. Adjust the vent line(s) so that the outlet is at the same horizontal level as the needle port to prevent siphoning. (See Figure 2).

For other leakage or injection troubleshooting, refer to the Rheodyne Troubleshooting Guide for HPLC Injection Problems. You may download the Guide from the Rheodyne web site: www.idex-hs.com under Support.

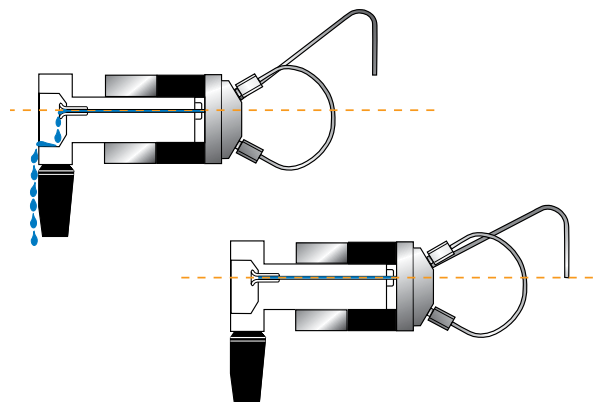

Figure 2 Needle port level compared to the level of vent line outlet: (A) siphoning occurs when the vent line outlet is above the needle port level; (B) siphoning does not occur if the vent line outlet is the same horizontal level as the needle port.

Application Note

Using Proper Syringe Needles

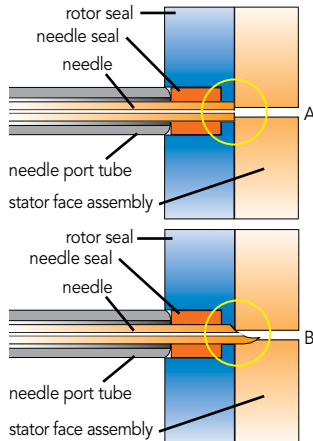

Figure 1 A square cut needle (A) stops against the stator face assembly. The tip of a pointed needle (B) slips into the stator face and the tip breaks off as the valve rotates.

With front-loading injectors it is important to use the correct needle when loading the sample loop. An incorrect needle will damage the valve and can cause poor reproducibility. When the needle is too short the tip will not reach the needle seal. When the needle is too small in diameter the seal will not grip tightly enough. Needles with a beveled tip can damage the rotor seal and stator face assembly (see Figure 1). The needle should be #22 gauge, and 90° point style (square cut end). Model 3725 requires a #16 gauge needle. NEVER USE A BEVELED, POINTED, OR TAPERED NEEDLE.

Needle specifications are not critical when using a Loop Filler Port to load the sample loop. However, it is important to tighten the needle port fitting around the needle if using a syringe needle with a slightly smaller diameter than 0.7 mm (0.028").

If the loading method used is complete-filling, a syringe without a needle can be used. A syringe fitted with a Needle Port Cleaner can be used with a front-loading valve (Figure 2A) or with a Loop Filler Port (Figure 2B).

Needle port accessories are listed on this page.

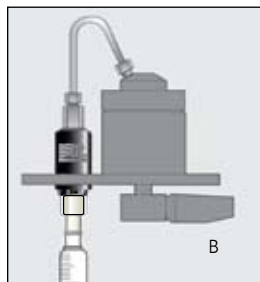

Figure 2 (A) Syringe fitted with Needle Port Cleaner (Part # 7125-054) loading a front-loading valve (model 7725); (B) loading a Loop Filler Port (Part # 7012).

Needle Port Accessories

Rheodyne's adaptable Loop Filler Ports (Part #7012 and 9012) are used to load sample from syringe needles or luer tips. The Needle Port (Part #9013) conserves sample by minimizing the volume between the needle and the valve.



Valve Adapter for 10-32 Ports

- ▶ For 1/32" OD Stainless Steel Tubing
- ▶ Low Swept Volume
- ▶ Extends the Life of the Rotor

As a result of customer requests, Upchurch Scientific® has created a Valve Adapter for 10-32 ports designed specifically for use with 1/32" OD stainless steel tubing. This product extends the life of and prevents damage to the rotor, guarding against such potential hazards as tubing that may pass through the stator and scratch the rotor. The Valve Adapter protects the rotor without adding significant volume. In fact, this adapter has a very low swept volume, at 300 nL. Additionally, the all-PEEK™ fluid pathway ensures biocompatibility.

M-400

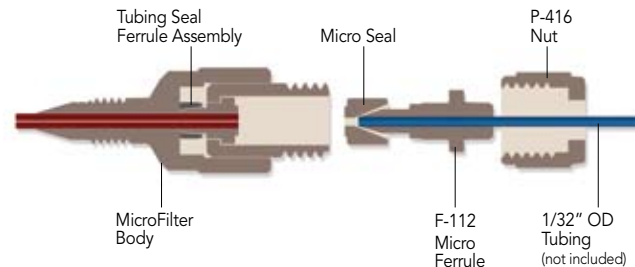

M-400

Valve Adapter
(Includes indicated products)

NEEDLE PORT ACCESSORIES

7012	Stainless Steel Loop Filler Port
9012	PEEK Loop Filler Port
9013	PEEK Needle Port
7125-054	Needle Port Cleaner
9125-076	Suction Needle Adapter (for model 9725)

VALVE ADAPTER FOR 10-32 PORTS

F-112	Replacement MicroFerrule for M-400, Natural PEEK
M-400	Valve Adapter Assembly
P-416	Replacement Female Nut for M-400, Natural PEEK

Micro Injection Port Adapters

- ▶ For 1/32" or 360 µm OD Tubing
- ▶ Mount on Actuator, Bracket or Bulkhead

To introduce sample, connect 1/32" or 360 µm OD capillary tubing to an Upchurch Scientific Injection Port Adapter Assembly. These adapters accept standard 22 gauge Hamilton-style injection syringe needles. No additional swept volume is added to the fluid pathway by these adapters, as the needle butts directly against the connecting tubing during injections. The adapters can be bulkhead mounted or mounted with the V-447 Kits. Refer to the chart below to select the appropriate adapter assembly.

To introduce a sample directly into a 10-32 port, purchase a M-432-03 separately.

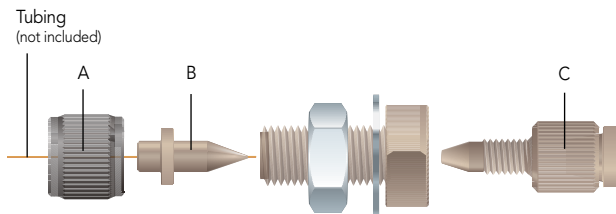

M-432
Micro Injection Port Adapter Assembly

Mounting Brackets

Rheodyne® mounting brackets and panels of different shapes and sizes organize and provide a sturdy support for Rheodyne valves. The Ring Stand Mounting Bracket now allows the valves to mount onto common laboratory equipment.



	Replacement Parts*		
	A	B	C
For 1/32" OD Tubing			
M-433	P-416	F-112	M-432-03
For 360 µm OD Tubing			
M-432 and V-447	P-416BLK	F-152	M-432-03

*See diagram above.

Rheodyne Wrench

The smartly designed Rheodyne Wrench is a double-ended slotted socket wrench that fits over 1/16" and 1/8" OD tubing. It easily loosens and tightens 1/4" and 5/16" stainless steel or PEEK™ fittings. The "Z" shape of the Rheodyne Wrench provides ideal leverage for changing sample loops and fittings, and keeps one end from restricting the use of the other.



MICRO INJECTION PORT ADAPTERS	
For 1/32" OD Tubing	
F-112	Replacement MicroFerrule for M-433, Natural PEEK™
M-433	Micro Injection Port Adapter Assembly
M-432-03	Replacement Tubing/Fitting Assembly for M-432 & M-433
P-416	Replacement Female Nut for M-433, Natural PEEK
For 360 µm OD Tubing	
F-152	Replacement MicroFerrule for M-432, Natural PEEK
M-432	Micro Injection Port Adapter Assembly
M-432-03	Replacement Tubing/Fitting Assembly for M-432 & M-433
P-416BLK	Replacement Female Nut for M-432, Black PEEK
V-447	Micro Injection Port Adapter Assembly Actuator Mounting Kit Includes (1) M-432 with mini-actuator bracket and (2) mounting screws

RHEODYNE WRENCH	
6810	Rheodyne Wrench
MOUNTING BRACKET ACCESSORIES	
7160	Mounting Panel
7160-010	Valve Angle Bracket
7160-029	Ring Stand Mounting Bracket